

8 7 6 5 4 3 2 1

REVISIONS				
ZONE	REV.	DESCRIPTION	DATE	APPROVED
	A	E-Number	2020-10-27	svma

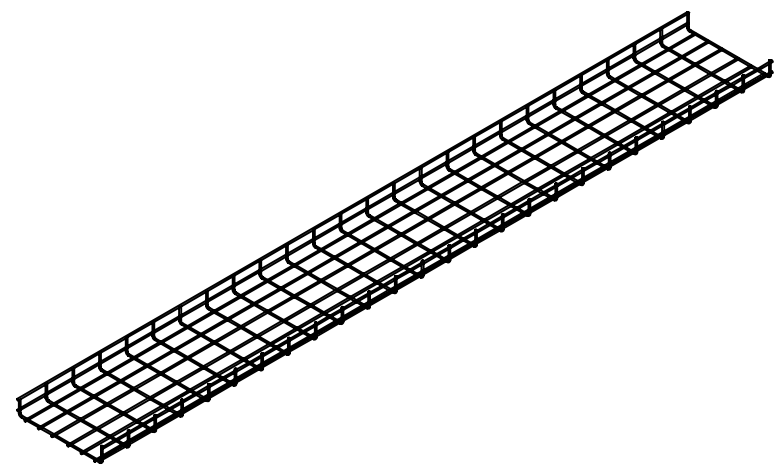
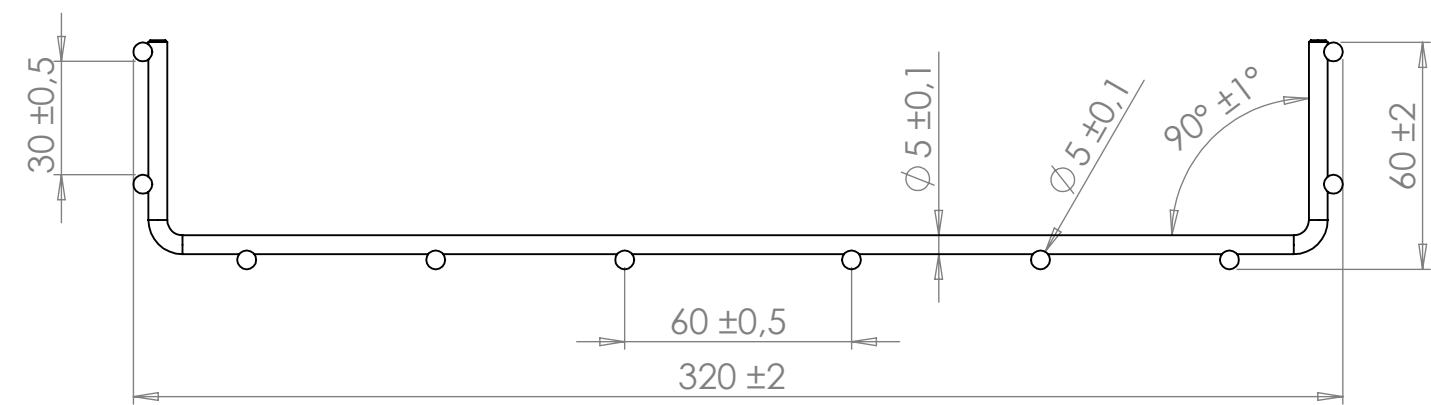
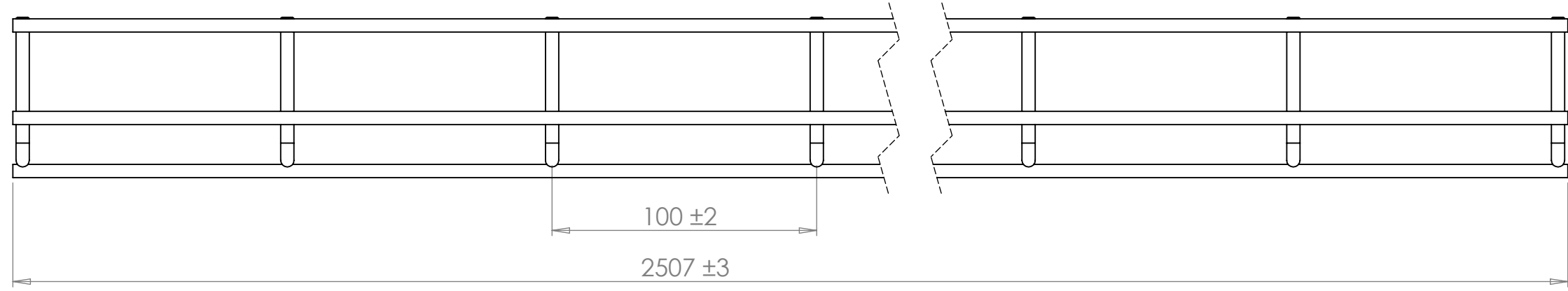

Part Number	E-Number	Surface
0142	1133105	Zink plated DIN 50961
0242	1133119	Hot dip galvanzied DIN 50979
0342	1133133	Acid proof AISI 316L
0442	1133147	Stainless Steel AISI 304L

© 2018 Axellent AB



C-number C-0005733-01	Material
Description X-Tray 320x60x2500	Part / Assembly-ID Default(A-0004897)
Unless otherwise specified: SS-ISO 2768-1 MEDIUM	Rev. A.0 Sheet Name Sheet1
	Rev. B.1 Sheet A3
	Scale 1:20
	Weight (calculated) 5,47 kg

Finish / Color	Created By suem
	Created 2011-08-12
	Changed 2020-10-27
	svma

8 7 6 5 4 3 2 1