

Warning: This drawing and associated computer data is the property and copyright of Axelent AB Sweden. These must not be copied, brought to the knowledge of a third party or used without our written authorization.

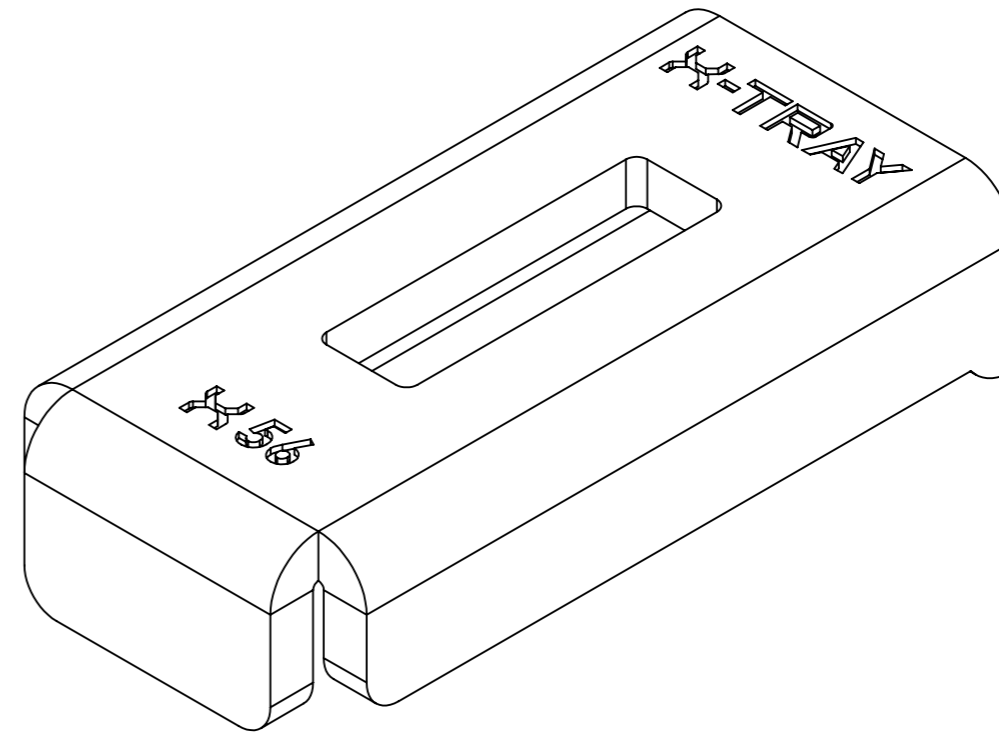
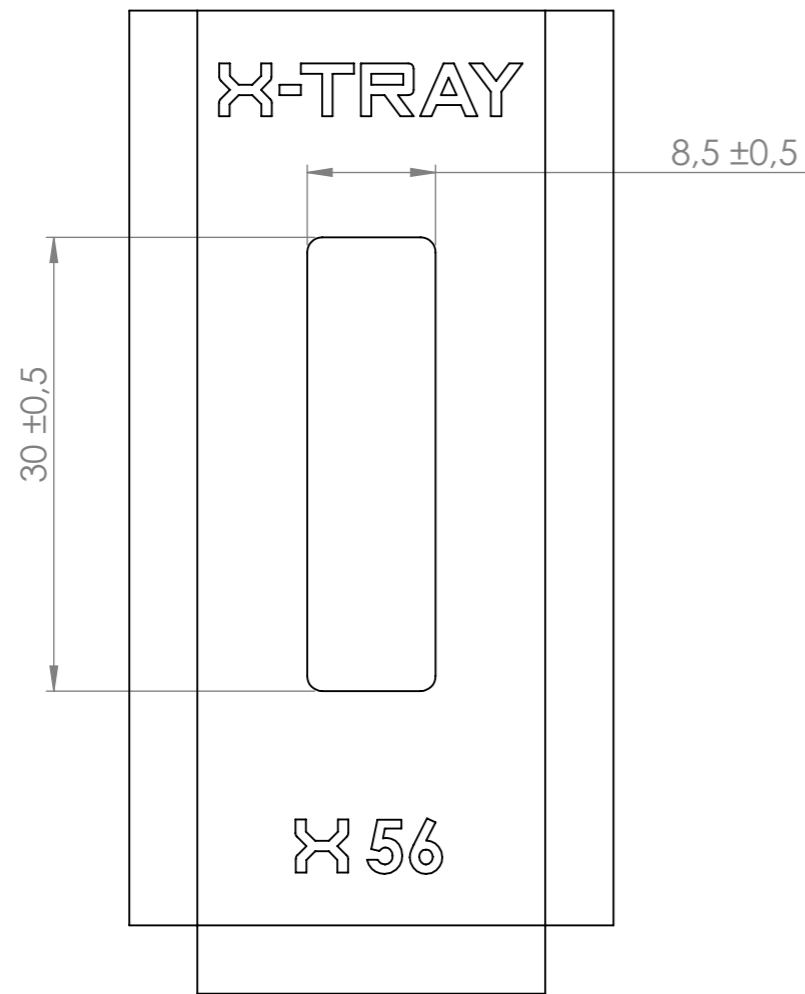
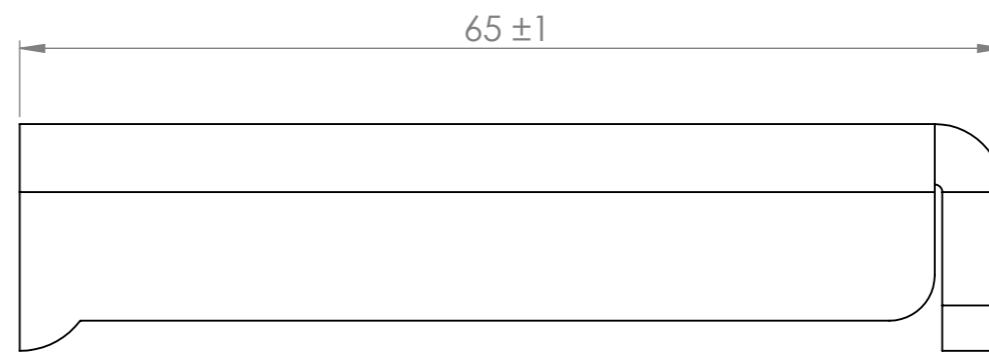
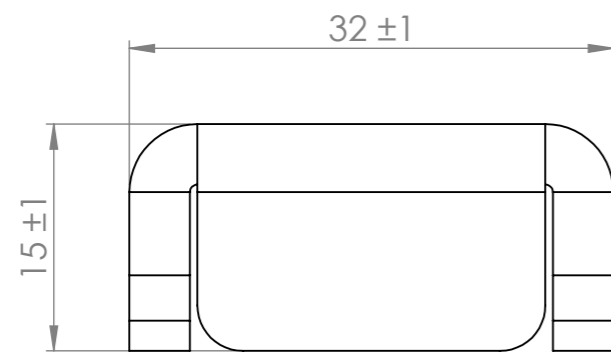

Part No.	Surface
2156	Zinc Plated DIN 50961
2256	Hot dip galvanized DIN 50976
2356	Acid proof AISI 316L

© 2020 Axelent AB		 Axelent AB +46 (0)370 37 37 30 Hillerstorp, Sweden		Dimensions not stated on drawing see valid 3D model. Unless otherwise specified; SS-ISO 2768-1 MEDIUM <input type="checkbox"/> Inspection characteristics.	
C-number		Material		Finish / Color	
Description		Part / Assembly-ID		Created By	
X56 U-Bar Clamp		Default(A-0024729)		svma	
		Drawing-ID		Created	
		2056-KR		2020-12-30	
		Weight (calculated)		Changed	
		92 g		2021-02-12	
		Scale		svma	
		2:1			