

8 7 6 5 4 3 2 1

REVISIONS				
ZONE	REV.	DESCRIPTION	DATE	APPROVED
	A	E-Number	2020-10-27	svma

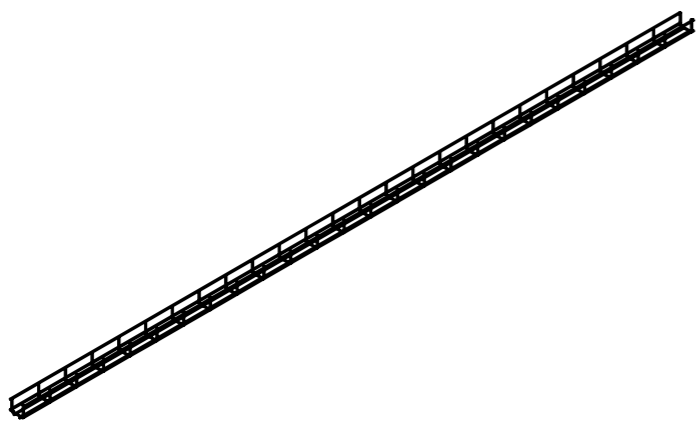

Article number	E-Number	Surface
0199-053	1133111	Zink plated DIN 50961
0299-053	1133125	Hot dip galvanized DIN 50979
0399-053	1133139	Acid proof AISI 316L
0499-053	1133153	Stainless Steel AISI 304L

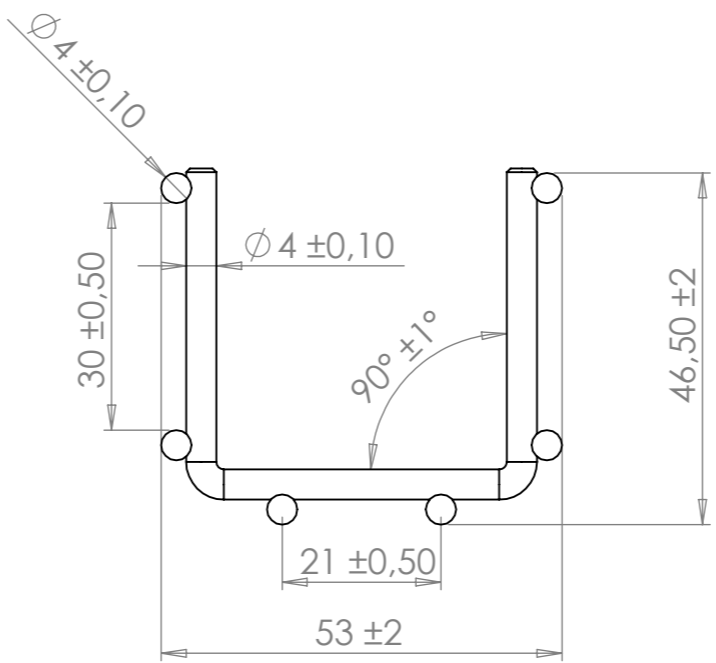
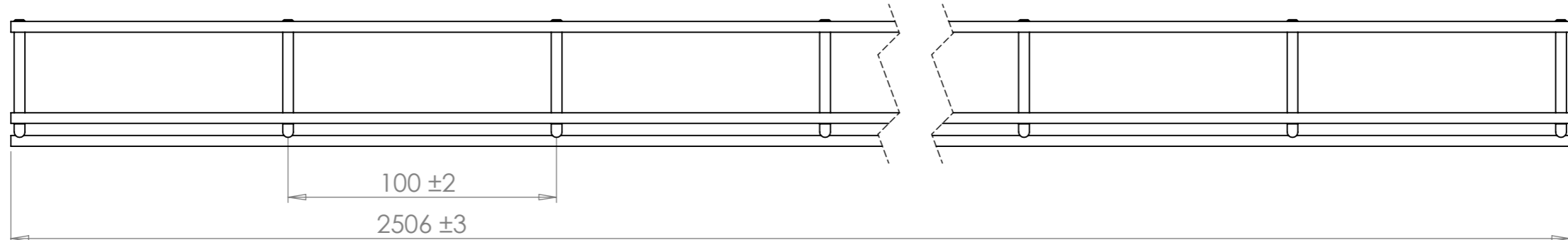

C-number	Material
C-0005784-01	Part / Assembly-ID
Description	Rev.
X-Tray 53x46x2500	A.0
Unless otherwise specified: SS-ISO 2768-1 MEDIUM	C.0

Material	Finish / Color	Created By
Weight (calculated)	Scale	svem
1,79 kg	1:20	Created
		2012-01-16
		Changed
		2020-10-27
		svma

8 7 6 5 4 3 2 1