

8 7 6 5 4 3 2 1

REVISIONS				
ZONE	REV.	DESCRIPTION	DATE	APPROVED
	A	E-Number	2020-10-27	svma

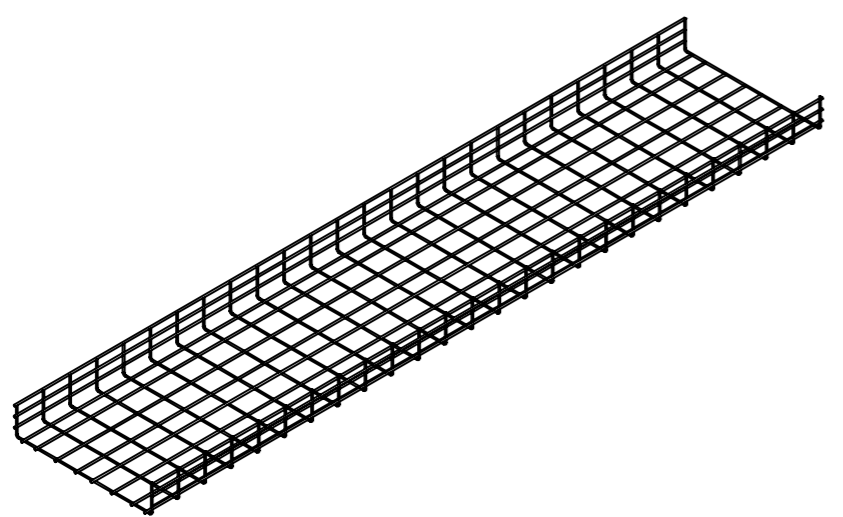

Part Number	E-Number	Surface
0152	1133109	Zink plated DIN 50961
0252	1133123	Hot dip galvanized DIN 50979
0352	1133137	Acid proof AISI 316L
0452	1133151	Stainless Steel AISI 304L

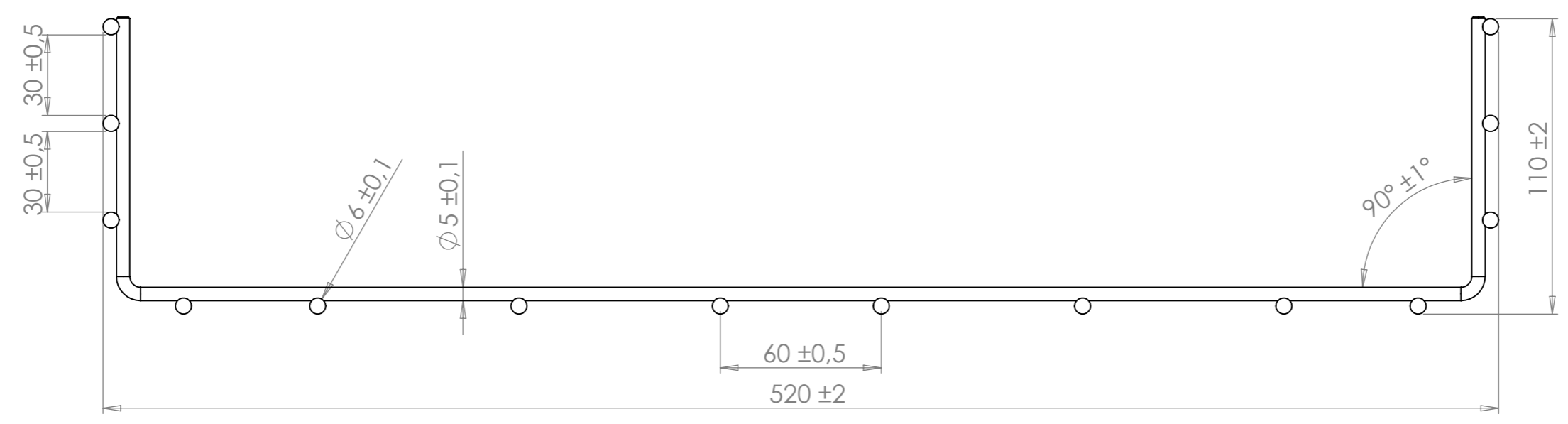
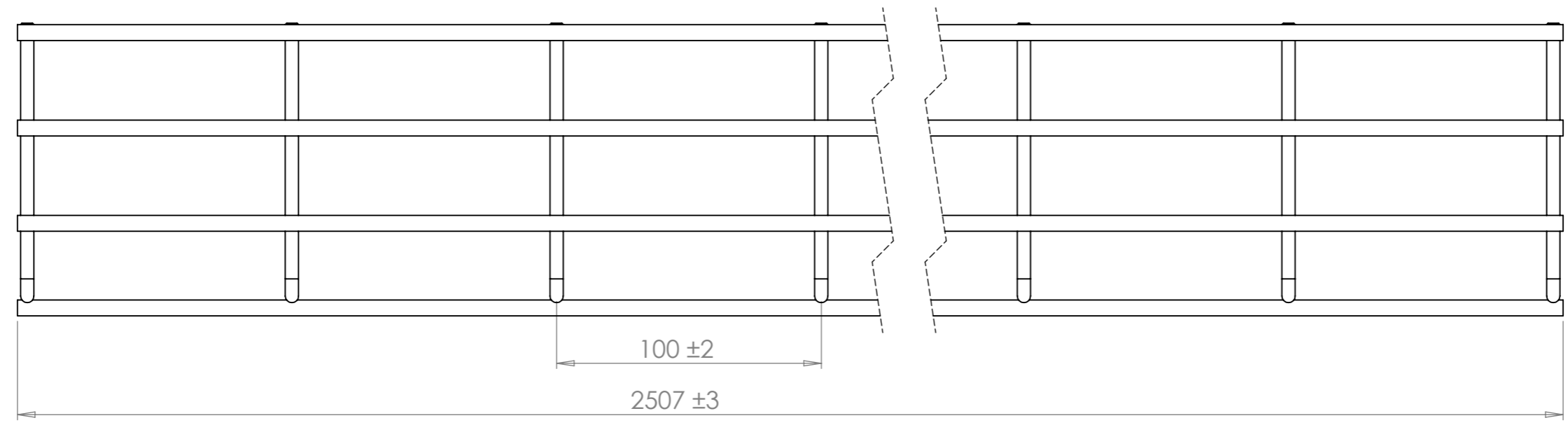

C-number C-0005776-01	Material	Finish / Color	Created By suem
Description X-Tray 520x110x2500	Part / Assembly-ID Default(A-0005047)	Rev. A.0 Sheet1	Created 2011-08-17
Unless otherwise specified: SS-ISO 2768-1 MEDIUM	Drawing-ID KR-0052	Rev. B.1 A3	Changed 2020-10-27 svma
	Weight (calculated) 10,59 kg	Scale 1:20	

8 7 6 5 4 3 2 1